

Multifunctional room sensor and measuring transducer
for humidity, temperature, air quality (VOC), fine dust (PM) and CO2 content,
calibratable, with Modbus connection

RFTM - CO2 - Modbus - P
 with display and potentiometer

Multifunctional indoor climate sensor **AERASGARD® RFTM - LQ - PS - CO2 - Modbus** (maximum expansion level) with Modbus connection, in an elegant plastic housing with snap-on lid, base with 4-hole attachment, optionally with / without display, type variant **RFTM - CO2 - Modbus** optionally with / without setpoint potentiometer. The room sensor is used for detecting the air humidity (0...100% RH), room temperature (0...+50 °C / +32...+122 °F), air quality (VOC) (0...100%), the fine dust (PM) (0...1000 µg/m³) and CO2 content (0...5000 ppm) as well as a room control unit (% setpoint). International system of units **SI** (default) can be changed to **imperial** (via Modbus). The following parameters can be accessed via the Modbus: Temperature, relative humidity, air quality (VOC), fine dust (PM) and carbon dioxide (CO2). Use just one device to monitor and control the entire indoor climate effectively. This enables energy-saving room ventilation on an as-needed basis, thereby reducing operating costs and improving well-being. It is used in offices, hotels, convention centres, apartments, shops, etc. One sensor for every 30 m² of room area is recommended.

A long-term stable, **digital humidity and temperature sensor** guarantees exact measurement results. The CO2 measurement is performed using an optical **NDIR sensor** (non-dispersive infra-red technology). The air quality is detected by a **VOC sensor** (mixed gas sensor for volatile organic substances). With regard to the expected air contamination, low (SLOW), medium (NORMAL) or high (FAST) VOC sensitivity can be selected. An optical **fine dust sensor** precisely detects **particulate (PM)** of the size category 0.3 to 10 micrometres.

Innovative Modbus sensor with galvanically separated RS485-Modbus-interface, selectable bus termination resistance, DIP switch for setting the bus parameters and bus address in current-free state, internal LEDs for telegram status display, two separate push-in terminals and two-line display (illuminated; with customised programming in the 7-segment and dot-matrix range). The sensor is factory-calibrated; an environmental precision adjustment by an expert is possible.



TECHNICAL DATA

Power supply:	24 V AC / DC (± 10 %)
Power consumption:	typical < 4.4 W / 24 V DC; < 6.4 VA / 24 V AC; peak current 200 mA
Communication:	Modbus (RTU cable)
Bus interface:	RS 485, galvanically isolated
Baud rate:	9600, 19200, 38400 Baud
Bus protocol:	Modbus (RTU mode), address range 0... 247 adjustable
Signal filtering:	4 s / 32 s
System of units:	SI (default) or imperial (can be changed via Modbus)
Data points:	Temperature [°C] [°F], Relative humidity [% RH], Air quality (VOC) [%], Fine dust (PM) [µg/m³], Carbon dioxide (CO2) [ppm], Setpoint potentiometer [%]

HUMIDITY & TEMPERATURE

Sensor:	digital humidity sensor with integrated temperature sensor , low hysteresis, high long-term stability
Measuring range:	0...100% RH (humidity) 0...+50 °C / +32...+122 °F (temperature)
Accuracy, humidity:	typical ± 2.0% (20...80% RH) at +25 °C, otherwise ± 3.0%
Accuracy, temperature:	typical ± 0.2 K at +25 °C

AIR QUALITY (VOC)

Sensor:	VOC sensor (metal oxide) with automatic air quality algorithm (volatile organic compounds)
Measuring range:	0...100% air quality (0% = clean air / 100% = polluted air), referred to calibrating gas, multi-range switching, VOC sensitivity SLOW / NORMAL / FAST (selectable via DIP switches)
Accuracy:	typical ± 20% of final value (referred to calibrating gas)
Service life:	> 60 months (under normal load conditions)

FINE DUST (PM)

Sensor:	optical particulate sensor (PM = particulate matter) , fine-dust sensor with laser- and soiling-resistant technology
Measuring range:	0...1000 µg/m³
Particle size:	PM 2.5 (0.3...2.5 µm); PM 10 (0.3...10 µm)
Accuracy:	typical ± 10 µg/m³ (± 10% of measured value) at PM 2.5 typical ± 25 µg/m³ (± 25% of measured value) at PM 10
Long-term stability:	± 1.25 µg/m³ (± 1.25% of measured value per year)
Service life:	> 10 years

CARBON DIOXIDE (CO2)

Sensor:	optical NDIR sensor (non-dispersive infra-red technology) with manual calibration (via zero button), with automatic calibration (can be deactivated via Modbus)
Measuring range:	0...5000 ppm
Accuracy:	typical ± 30 ppm ± 3% of measured value
Temperature dependence:	± 5 ppm per °C or ± 0.5% of measured value per °C (whichever is higher)
Pressure dependence:	± 0.13% per mm Hg
Long-term stability:	< 2% in 15 years

Continued on next page!

Display screen standard	Modbus (Baldur)
	Carbon dioxide (CO2) (ppm)
	Air quality (VOC) [%]
	Temperature [°C] [°F]
	Humidity [% RH]
	Fine dust (PM) [µg/m³]

Display screen programmable	Modbus (Baldur)
	Symbols



S+S REGELTECHNIK

AERASGARD® RC02 / RLQ-CO2 - Modbus AERASGARD® RFTM-LQ-PS-CO2 - Modbus

Multifunctional room sensor and measuring transducer
for humidity, temperature, air quality (VOC), fine dust (PM) and CO2 content,
calibratable, with Modbus connection

Dimensional drawing
(mm)

Housing Baldur 2

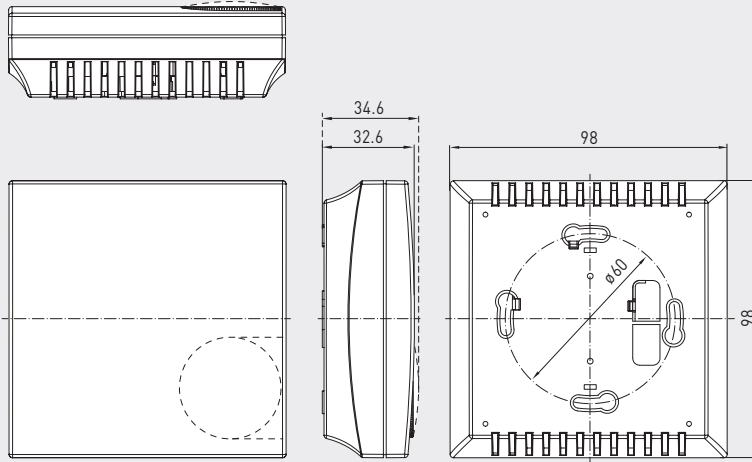

R xx CO2 - Modbus
without display



RFTM-LQ-PS-CO2 - Modbus
with display

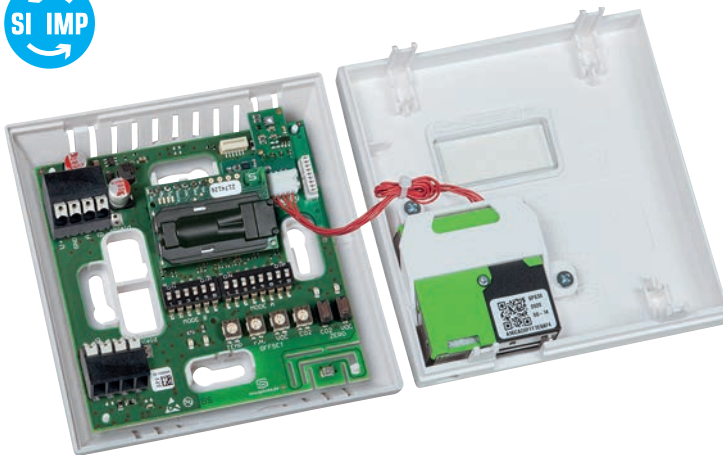

TECHNICAL DATA

(continued)

Warm up time:	approx. 1 hour
Response time:	< 2 minutes
Gas exchange:	by diffusion
Ambient temperature:	0...+50 °C
Permitted humidity:	0...95% RH (non-precipitating air)
Electrical connection:	0.2 - 1.5 mm ² , via push-in terminal
Housing:	Plastic, flame retardant (UL 94 V-0), PC/ABS material, colour white (similar to RAL 9016)
Housing dimensions:	98 x 98 x 33 mm (Baldur 2)
Installation:	Wall mounting or on in-wall flush box, Ø55 mm, base with 4-hole for mounting on vertically or horizontally installed in-wall flush boxes for cable entry from the back, with predetermined breaking point for on-wall cable entry from top/bottom in case of plain on-wall installation
Protection class:	III (according to EN 60 730)
Protection type:	IP 30 (according to EN 60 529)
Standards:	CE conformity according to EMC Directive 2014 / 30 / EU, Low Voltage Directive 2014 / 35 / EU
Optional:	Display with illumination , two line, cutout approx. 36 x 15 mm (W x H), to display actual humidity, actual temperature, air quality, of the fine-dust and CO2 content (cyclic) or a selectable parameter (static) or an individually programmable display value

Multifunctional room sensor and measuring transducer
 for humidity, temperature, air quality (VOC), fine dust (PM) and CO2 content,
 calibratable, with Modbus connection

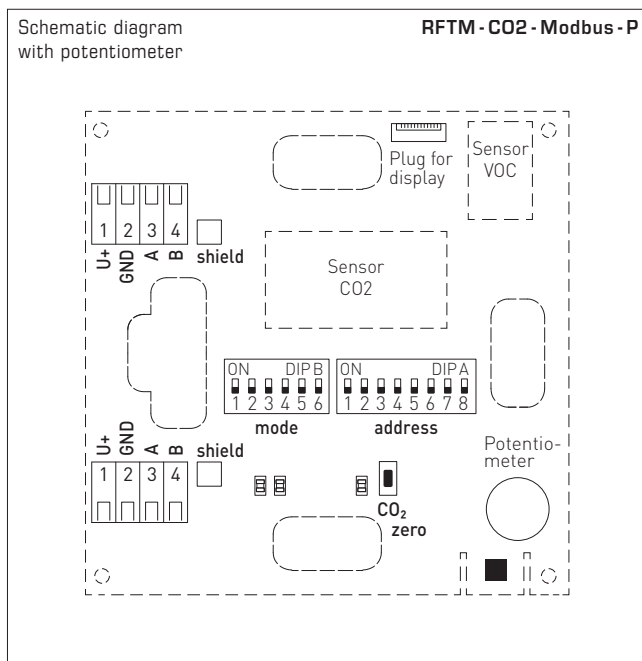
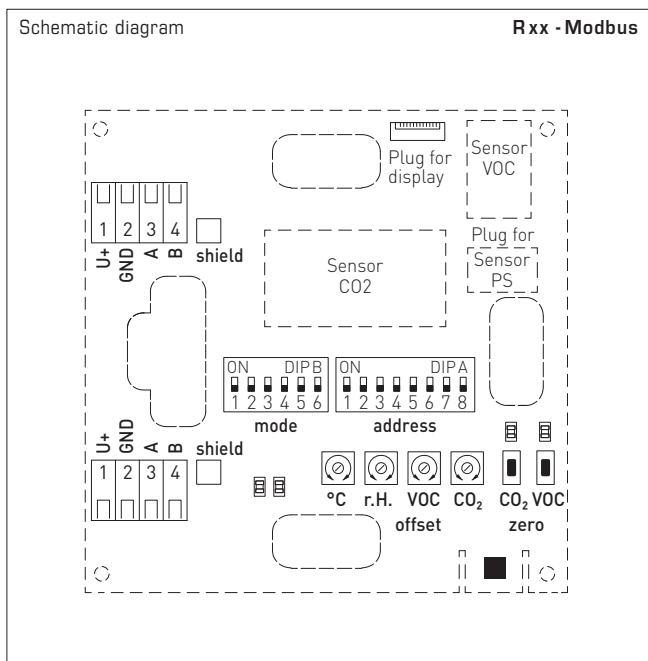

Display screen **standard (cyclic)**

Carbon dioxide (CO2)
 Air quality (VOC)
 Temperature [°C]
 Temperature [°F]
 Humidity
 Fine dust (PM)

Display screen **alternative (static)**

Carbon dioxide (CO2)
 Air quality (VOC)
 Temperature [°C]
 Temperature [°F]
 Humidity
 Fine dust (PM)

Display screen **Modbus programmable** (Baldur)

Symbols

The Modbus interface allows the display to be **individually** configured both in the 7-segment range and in the dot-matrix range. For improved legibility, backlighting is provided.



By default, the display indicates the measurements with the corresponding units **cyclically** and consecutively:

- CO2** content, **air quality** (VOC), **temperature**, **relative humidity**, **fine dust** (PM).

The **Modbus** configuration can be used to program an **alternative output variable** instead of the standard display. In this case, the first line indicates the value and index while the second line indicates the corresponding unit **statically**. The index identifies the display type:

- Index 1** = carbon dioxide (CO2) [ppm]
- Index 2** = air quality (VOC) [%]
- Index 3** = temperature [°C] [°F]
- Index 4** = relative humidity [%RH]
- Index 6** = fine dust (PM) [µg/m³]



S+S REGELTECHNIK

AERASGARD® RCO2 / RLQ-CO2 - Modbus AERASGARD® RFTM-LQ-PS-CO2 - Modbus

Multifunctional room sensor and measuring transducer
for humidity, temperature, air quality (VOC), fine dust (PM) and CO2 content,
calibratable, with Modbus connection

RFTM-CO2-Modbus-P
with setpoint potentiometer
(room control unit)



RFTM-LQ-PS-CO2-Modbus
with display



Rxx-CO2-Modbus
without display



AERASGARD® Rxx-Modbus		Room sensor and measuring transducer for humidity, temperature, air quality (VOC), fine dust (PM) and CO2 content, <i>Deluxe</i>						Price	
Type / WG02	Measuring ranges	Humidity	Temperature*	PM	CO2	VOC	Display ☼=P	Item No.	Price
RCO2-Modbus									
RCO2-Modbus	–	–	–	–	5000 ppm	–	–	1501-61B0-6001-200	300,78 €
RCO2-Modbus LCD	–	–	–	–	5000 ppm	–	■	1501-61B0-6021-200	355,78 €
RLQ-CO2-Modbus									
RLQ-CO2-Modbus	–	–	–	–	5000 ppm	0...100%	–	1501-61B1-6001-600	440,89 €
RLQ-CO2-Modbus LCD	–	–	–	–	5000 ppm	0...100%	■	1501-61B1-6021-600	495,87 €
RFTM-PS-Modbus									
RFTM-PS-Modbus	0...100% RH	0...+50 °C	0...1000 µg/m³	–	–	–	–	1501-2116-6001-200	409,94 €
RFTM-PS-Modbus LCD	0...100% RH	0...+50 °C	0...1000 µg/m³	–	–	–	■	1501-2116-6021-200	471,04 €
RFTM-CO2-Modbus									
RFTM-CO2-Modbus	0...100% RH	0...+50 °C	–	–	5000 ppm	–	–	1501-61B6-6001-200	354,91 €
RFTM-CO2-Modbus LCD	0...100% RH	0...+50 °C	–	–	5000 ppm	–	■	1501-61B6-6021-200	409,63 €
RFTM-CO2-Modbus-P with potentiometer									
RFTM-CO2-Modbus- P	0...100% RH	0...+50 °C	–	–	5000 ppm	–	☼	1501-61B6-6501-271	392,76 €
RFTM-CO2-Modbus- P LCD	0...100% RH	0...+50 °C	–	–	5000 ppm	–	☼ ■	1501-61B6-6521-271	447,73 €
RFTM-LQ-CO2-Modbus									
RFTM-LQ-CO2-Modbus	0...100% RH	0...+50 °C	–	–	5000 ppm	0...100%	–	1501-61B8-6001-600	480,94 €
RFTM-LQ-CO2-Modbus LCD	0...100% RH	0...+50 °C	–	–	5000 ppm	0...100%	■	1501-61B8-6021-600	535,91 €
RFTM-LQ-PS-CO2-Modbus									
RFTM-LQ-PS-CO2-Modbus	0...100% RH	0...+50 °C	0...1000 µg/m³	–	5000 ppm	0...100%	–	1501-2119-6001-600	621,32 €
RFTM-LQ-PS-CO2-Modbus LCD	0...100% RH	0...+50 °C	0...1000 µg/m³	–	5000 ppm	0...100%	■	1501-2119-6021-600	676,29 €
Housing variant "P":		Room control unit with potentiometer (standard printing is a widening arrow with central position unfilled)							
Note:		These units must not be used as safety-relevant devices!							
		* Temperatur: 0...+50 °C / +32...+122 °F International system of units SI (default) can be changed to imperial (via Modbus).							

ACCESSORIES			
KA2-Modbus	Communication adapter (USB/RS485) for system connection	1906-1200-0000-100	236,11 €
LA-Modbus	Line termination device (with terminating resistor) as an active bus termination	1906-1300-0000-100	88,05 €