

Duct hygrostats and humidity sensors ($\pm 2.0\%$), including mounting flange, electronic, one-step, with switching outputs

Electronic hygostat and humidity sensor **HYGRASREG® KH-40** with one switching output, adjustable switching threshold and display for displaying ACTUAL humidity (accuracy class $\pm 2.0\%$ RH) and for setting the target humidity. It is suitable for controlling and monitoring the relative air humidity, e.g. in ventilation and air conditioning ducts, laboratories, production rooms, climatic exposure test cabinets, swimming pools, greenhouses etc., for controlling humidifying and dehumidifying facilities. The measuring transducers are designed for exact detection of humidity. The KH-40 uses a digital, long-term stable sensor as a measuring element for measuring humidity. It is used in dust-free, unpolluted, non-aggressive air.

SF-K
Plastic sinter filter
(standard)



SF-M
Metal sinter filter
(optional)



MFT-20-K
Mounting flange,
plastic



Dimensional drawing [mm] **MFT-20-K**

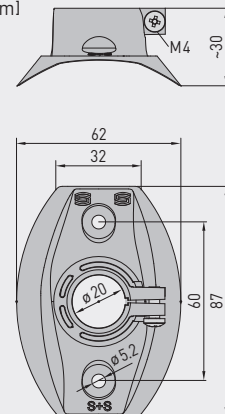

Display standard **KH-40**



TECHNICAL DATA

Power supply:	24 V AC ($\pm 20\%$) and 15...36 V DC
Power consumption:	< 1.1 VA / 24 V DC; < 2.2 VA / 24 V AC
Sensors:	digital humidity sensor , small hysteresis, high long-term stability
Sensor protection:	plastic sinter filter , \varnothing 16 mm, L = 35 mm, exchangeable (optional metal sinter filter , \varnothing 16 mm, L = 32 mm)
Setting range:	5...95 % RH
Output:	potential-free changeover contact (24 V), 1 A ohmic load
Accuracy, humidity:	typically $\pm 2.0\%$ (20...80 % RH) at +25 °C, otherwise $\pm 3.0\%$
Ambient temperature:	storage $-35...+85$ °C; operation $-30...+75$ °C, non-precipitating
Long-term stability:	$\pm 1\%$ per year
Housing:	plastic, UV-resistant, material polyamide, 30% glass-globe reinforced, with quick-locking screws (slotted / Phillips head combination), colour traffic white (similar to RAL 9016), housing cover for display is transparent!
Housing dimensions:	72 x 64 x 43.3 mm (Tyr 1 with display)
Cable connection:	cable gland , plastic (M 16 x 1.5; with strain relief, exchangeable, max. inner diameter 10.4 mm) or M12 connector according to DIN EN 61076-2-101 (on request)
Protective tube:	PLEUROFORM™ , material polyamide (PA6), with torsion protection, \varnothing 20 mm, NL = 235 mm (optionally 100 mm), $v_{max} = 30$ m/s (air) (on request, optional stainless steel V2A (1.4301), \varnothing 16 mm)
Process connection:	by mounting flange, plastic (included in the scope of delivery)
Electrical connection:	0.14 - 1.5 mm ² , via terminal screws
Protection class:	III (according to EN 60 730)
Protection type:	IP65 (according to EN 60 529) in the built-in state Housing tested, TÜV SÜD, Report No. 713139052 (Tyr 1)
Standards:	CE conformity according to EMC directive 2014 / 30 / EU
Display:	two-line display with illumination , cutout approx. 36 x 15 mm (W x H), for displaying actual humidit and for setting the target humidity
Displaying:	The 1st line of the display shows the relative humidity . The 2nd line shows on the left side the information regarding the switching status of the relay (as a circuit), as well as the switching value readout in % RH on the right side (adjustable using the set potentiometer). ○ Circuit, empty = relay in idle state ● Circuit, full = relay energised
FUNCTION	actual humidity < switching value contact 11-12 closed (LED OFF) actual humidity > switching value contact 11-13 closed (LED ON)



S+S REGELTECHNIK

HYGRASREG® KH-40

Duct hygrostats and humidity sensors ($\pm 2.0\%$), including mounting flange, electronic, one-step, with switching outputs

Dimensional drawing [mm]

KH-40

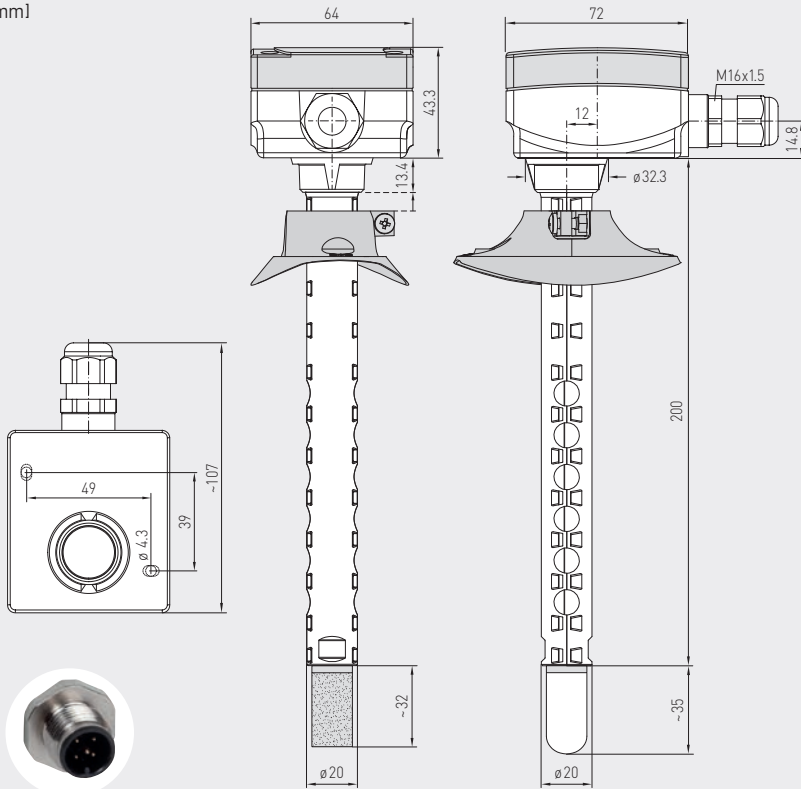

M12 connector (optional on request)

with metal sinter filter (optional)

with plastic sinter filter (standard)

KH-40 with display and plastic sinter filter (standard)



Schematic diagram

KH-40

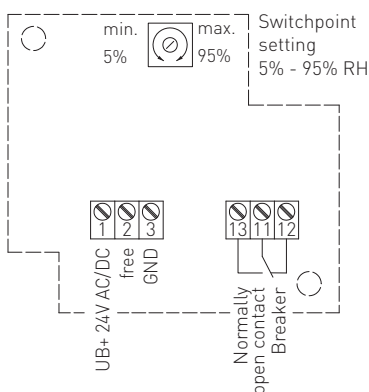

Connecting diagram

KH-40

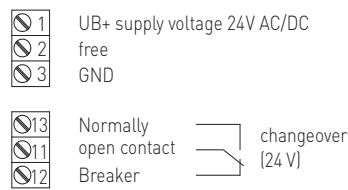

HYGRASREG® KH-40 Duct hygrostats and humidity sensors ($\pm 2.0\%$), Premium

Type/WG01	Setting range Humidity	Output	Steps	Display	Item No.	Price
KH-40						
KH-40W LCD	5...95% RH	1 x changeover contact	one-step	■	1202-3065-0221-000	201,48 €
Optional:	Cable connection with M12 connector according to DIN EN 61076-2-101 shortened protective tube PLEUROFORM™, NL = 100 mm				on request	on request

ACCESSORIES

SF-M	Metal sinter filter, \varnothing 16 mm, L = 32 mm, exchangeable, stainless steel V4A (1.4404)	7000-0050-2200-100	46,70 €
------	---	--------------------	---------