

HYGRASGARD® KFTF (20) - Modbus - T3

HYGRASGARD® KFTF (20) - wModbus



S+S REGELTECHNIK

Duct humidity- and temperature sensors ($\pm 1.8\%$ / $\pm 2.0\%$), incl. mounting flange, for mixture ratio, relative/absolute humidity, dew point, enthalpy and temperature, calibratable, with Modbus connection or W-Modbus (Wireless)

Calibratable duct humidity and temperature sensor **HYGRASGARD® KFTF-Modbus-T3** ($\pm 2.0\%$) or **KFTF-20-Modbus-T3** ($\pm 1.8\%$), with Modbus connection, in an impact-resistant plastic housing with quick-locking screws, optionally with/without display, with a plastic sinter filter (exchangeable), incl. mounting flange, to exactly detect the relative humidity (0...100% RH) and the temperature ($-35...+80\text{ }^\circ\text{C}$) and to detect various parameters in humidity measurement. International system of units **SI** (default) can be switched to **Imperial** (via Modbus). With **wModbus** device version, the W-Modbus (Wireless) replaces the RTU cable; the BMS connection is radio-based using a W-Modbus gateway.

The duct sensor is applied in a non-aggressive, dust-free environment and is suitable for installation in ceilings, ducts and devices. It is used in the refrigeration, air conditioning and clean room technology, engineering rooms, hotels and conference facilities.

A long-term stable, **digital humidity and temperature sensor** guarantee exact measurement results. These measurands are used to internally calculate the following parameters that can be retrieved via Modbus: relative humidity, absolute humidity, mixture ratio, dew point, enthalpy (ignoring atmospheric air pressure) and ambient temperature.

Innovative Modbus sensor with galvanically isolated RS485 Modbus interface, switchable bus terminating resistor, DIP switch for setting in current-free state, internal LEDs for telegram status display, push-in terminals and large three-line display (illuminated, individually programmable). The sensor is factory-calibrated; an environmental precision adjustment by an expert is possible.

KFTF (20) - Modbus - T3
without display
(RTU cable)



KFTF (20) - wModbus
without display
(wireless)



TECHNICAL DATA

Power supply:	24 V AC ($\pm 20\%$); 15...36 V DC
Power consumption:	< 1.2 W / 24 V DC; < 1.8 VA / 24 V AC
System of units:	SI (default) or Imperial (switchable via Modbus)
Data points:	temperature [$^\circ\text{C}$] [$^\circ\text{F}$], relative humidity [% RH], dew point [$^\circ\text{C}$] [$^\circ\text{F}$], absolute humidity [g/m^3] [gr/ft^3], mixing ratio [g/kg] [gr/lb], enthalpy [kJ/kg] [Btu/lb]
Sensor:	digital humidity sensor with integrated temperature sensor , low hysteresis, high long-term stability
Measuring range:	0...100% RH (humidity); $-35...+80\text{ }^\circ\text{C}$ (temperature)
Accuracy, humidity:	KFTF-xx : typically $\pm 2.0\%$ (20...80% RH) at $+25\text{ }^\circ\text{C}$, otherwise $\pm 3.0\%$ KFTF20-xx : typically $\pm 1.8\%$ (10...90% RH) at $+25\text{ }^\circ\text{C}$, otherwise $\pm 2.0\%$
Accuracy, temperature:	typically $\pm 0.2\text{ K}$ at $+25\text{ }^\circ\text{C}$
Zero point offset:	$\pm 10\%$ RH (humidity); $\pm 5\text{ }^\circ\text{C}$ (temperature)
Ambient temperature:	$-30...+70\text{ }^\circ\text{C}$
Medium:	clean air and non-aggressive, non-combustible gases
Communication:	Modbus (RTU cable), Bus interface RS 485, galvanically isolated , Baud rate 9600, 19200, 38400 baud or W-Modbus (Wireless Modbus, AES-128 encrypted) Frequency 2.4 GHz ISM, Transmission power 100 mW , Range max. 500 m (open field) / approx. 50 - 70 m (inside buildings)
Bus protocol:	Modbus (RTU mode), address range 0... 247 selectable
Signal filtering:	4 s / 32 s
Sensor protection:	plastic sinter filter, \varnothing 16 mm, L = 35 mm, exchangeable (optional metal sinter filter, \varnothing 16 mm, L = 32 mm)
Protective tube:	PLEUROFORM™ , material polyamide (PA6), with torsion protection, \varnothing 20 mm, NL = 235 mm (optionally 100 mm), $v_{\text{max}} = 30\text{ m/s}$ (air) (optionally made of stainless steel V2A (1.4301), \varnothing 16 mm)
Housing:	plastic, UV-resistant, material polyamide, 30% glass-globe reinforced, with quick-locking screws (slotted/Phillips head combination), colour traffic white (similar to RAL 9016), housing cover for display is transparent!
Housing dimensions:	108 x 78.5 x 43.3 mm (Tyr 3 without display) 108 x 78.5 x 45.8 mm (Tyr 3 with display)
Cable connection:	cable gland , plastic (M20 x 1,5; with strain relief, exchangeable, inner diameter 8 - 13 mm) or M12 connector according to DIN EN 61076-2-101 (optional on request)
Electrical connection:	0.2 - 1.5 mm ² , using push-in terminals
Process connection:	by mounting flange, plastic (included in the scope of delivery)
Permissible air humidity:	< 95% RH, non-precipitating air
Protection class:	III (according to EN 60 730)
Protection type:	IP 65 (according to EN 60 529)
Standards (Modbus):	CE conformity according to EMC Directive 2014 / 30 / EU
Standards (W-Modbus):	CE conformity according to Radio Directive 2014 / 53 / EU
Features:	display with illumination , three-line, programmable, cutout approx. 51 x 29 mm (W x H), for displaying the actual humidity and actual temperature (cyclic) or a selectable parameter (static) or an individually programmable display value

Programmable display screen **Tyr 3**





NEW

S+S REGELTECHNIK

HYGRASGARD® KFTF (20)-Modbus-T3 HYGRASGARD® KFTF (20)-wModbus

Duct humidity- and temperature sensors ($\pm 1.8\%$ / $\pm 2.0\%$), incl. mounting flange, for mixture ratio, relative/absolute humidity, dew point, enthalpy and temperature, calibratable, with Modbus connection or W-Modbus (Wireless)

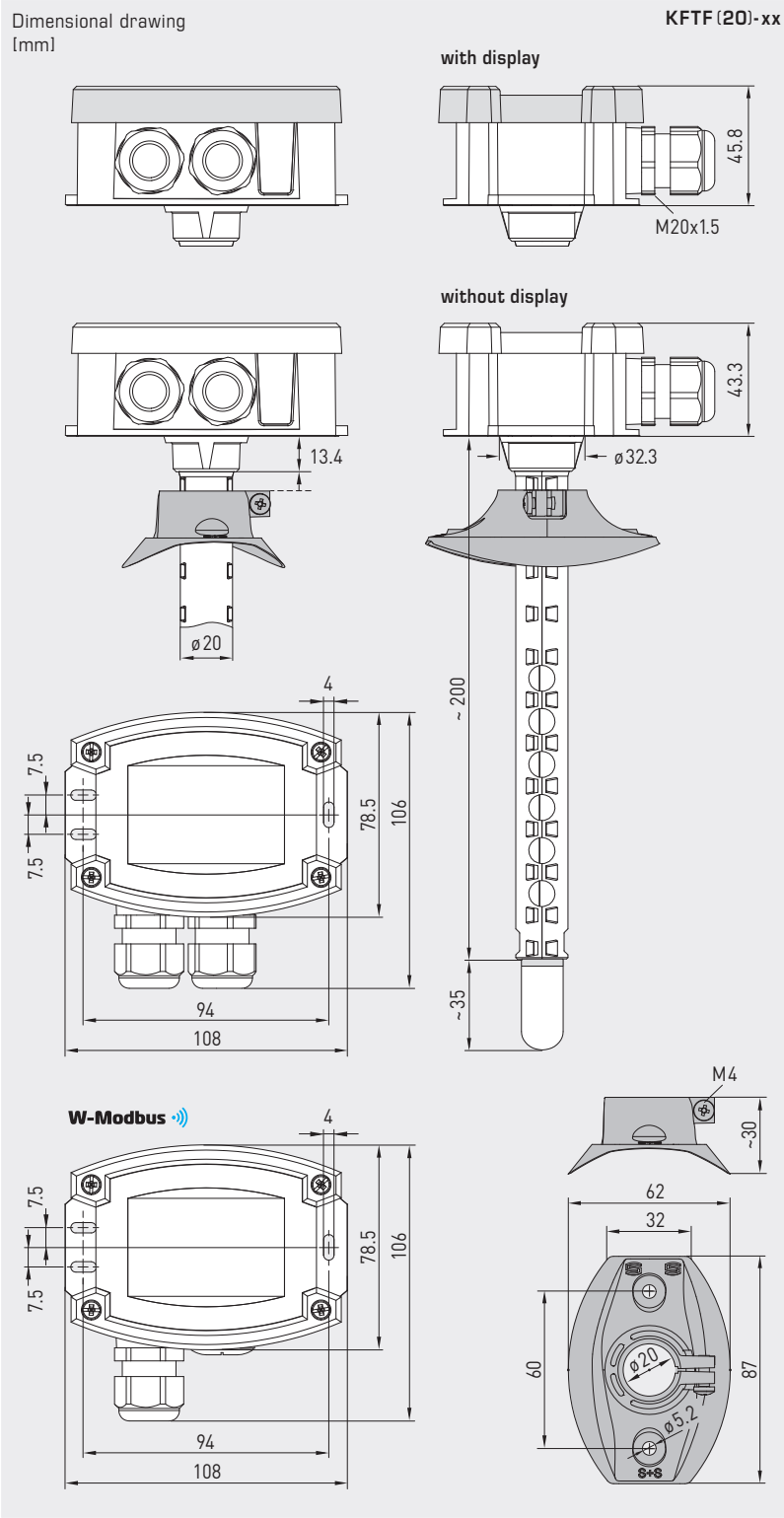

Device version with **M12 connector** (optional on request)



MFT-20-K
Mounting flange, plastic



SF-K
Plastic sinter filter (standard)



SF-M
Metal sinter filter (optional)



stainless steel protective tube (optional on request)

HYGRASGARD® KFTF (20)-Modbus-T3

HYGRASGARD® KFTF (20)-wModbus



Duct humidity- and temperature sensors ($\pm 1.8\%$ / $\pm 2.0\%$), incl. mounting flange, for mixture ratio, relative/absolute humidity, dew point, enthalpy and temperature, calibratable, with Modbus connection or W-Modbus (Wireless)

S+S REGELTECHNIK

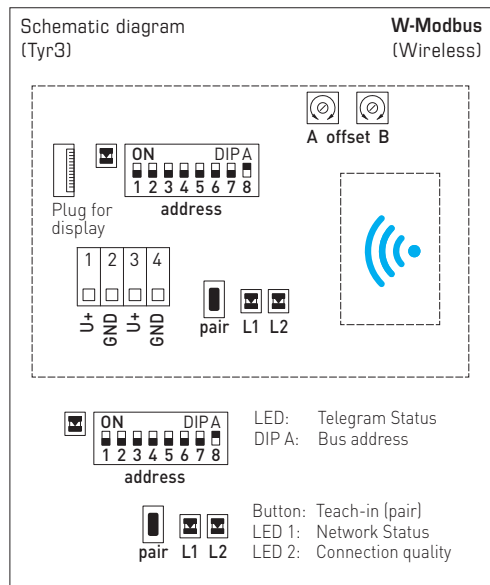
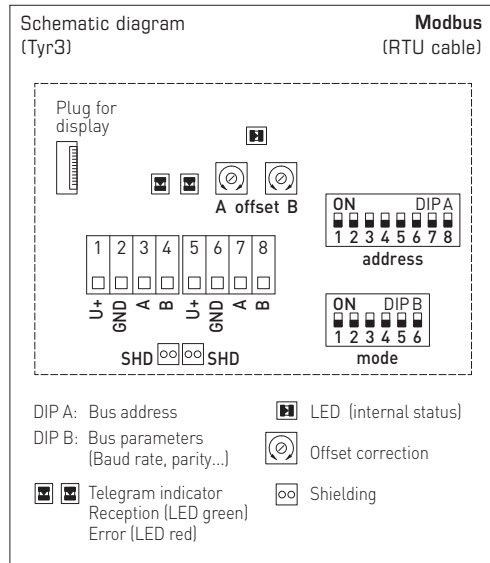

MODBUS ACCESSORIES

GW-wModbus	Gateway with W-Modbus (Wireless) for radio-based connection to Modbus networks, operating modes 'Gateway' (basic function as a base station) and 'Node' (adapter function for max. 1 wired sensor)	1801-1211-1101-000	245,30 €
GW-wModbus Pro	and 'Node Pro' (adapter function for max. 16 wired sensors)	1801-1211-1101-100	332,07 €
KA2-Modbus	Communication adapter (USB/RS485) for system connection	1906-1200-0000-100	236,11 €
LA-Modbus	Line termination device (with terminating resistor) as an active bus termination	1906-1300-0000-100	88,05 €

For further information see the end of the chapter!

ACCESSORIES

SF-M	Metal sinter filter, \varnothing 16 mm, L = 32 mm, exchangeable, stainless steel I V4A (1.4404)	7000-0050-2200-100	46,70 €
SF-K	Plastic sinter filter, \varnothing 16 mm, L = 35 mm, exchangeable (included in the scope of delivery)	7000-0050-2310-000	14,19 €
MFT-20-K	Mounting flange, plastic (included in the scope of delivery)	7100-0030-4000-000	10,55 €

For further information, see last chapter Accessories!



NEW

S+S REGELTECHNIK

HYGRASGARD® KFTF (20)-Modbus-T3 HYGRASGARD® KFTF (20)-wModbus

Duct humidity- and temperature sensors ($\pm 1.8\%$ / $\pm 2.0\%$), incl. mounting flange, for mixture ratio, relative/absolute humidity, dew point, enthalpy and temperature, calibratable, with Modbus connection or W-Modbus (Wireless)

KFTF (20)-wModbus
with / without display
(wireless)

KFTF (20)-Modbus-T3
with / without display
(RTU cable)



HYGRASGARD® KFTF (20) - Modbus-T3
KFTF (20) - wModbus

Duct humidity- and temperature sensors ($\pm 1.8\%$ / $\pm 2.0\%$) with with Modbus connection (RTU cable) or with W-Modbus (Wireless)

Modbus W-Modbus

Type / WG01	Measuring Range / Readout Humidity (switchable)	Temperature	Output	Display	Item No.	Price
KFTF-xx		$\pm 2.0\%$ RH				
KFTF-Modbus-T3	0...100% RH (default) 0...80 g/kg (MV) 0...80 g/m ³ (AH) 0...85 kJ/kg (ENT.) 0...+50°C (DP)	-35...+80°C	Modbus (RTU cable)		1201-32C6-1000-029	230,75 €
KFTF-Modbus-T3 LCD	(5x as above)	(1x as above)	Modbus (RTU cable)	■	1201-32C6-1400-029	291,43 €
KFTF-wModbus	(5x as above)	(1x as above)	W-Modbus (Wireless)		1201-32CF-1000-029	273,60 €
KFTF-wModbus LCD	(5x as above)	(1x as above)	W-Modbus (Wireless)	■	1201-32CF-1400-029	334,28 €
KFTF 20-xx		$\pm 1.8\%$ RH				
KFTF-20-Modbus-T3	0...100% RH (default) 0...80 g/kg (MV) 0...80 g/m ³ (AH) 0...85 kJ/kg (ENT.) 0...+50°C (DP)	-35...+80°C	Modbus (RTU cable)		1201-32C6-1000-030	301,64 €
KFTF-20-Modbus-T3 LCD	(5x as above)	(1x as above)	Modbus (RTU cable)	■	1201-32C6-1400-030	454,45 €
KFTF-20-wModbus	(5x as above)	(1x as above)	W-Modbus (Wireless)		1201-32CF-1000-030	344,48 €
KFTF-20-wModbus LCD	(5x as above)	(1x as above)	W-Modbus (Wireless)	■	1201-32CF-1400-030	497,29 €
Optional:	Cable connection with M12 connector according to DIN EN 61076-2-101 shortened protective tube PLEUROFORM™ , NL = 100 mm Protective tube made of stainless steel				on request	on request
Note:	System of units SI (default) or imperial (can be changed via Modbus).					