

**Gateway with W-Modbus module,
for radio-based connection to Modbus networks**

S+S REGELTECHNIK

The gateway KYMASGARD® GW-wModbus with Modbus connection and W-Modbus module, in an impact-resistant plastic housing with quick-locking screws, for on-wall installation, serves as a transition between wired Modbus and radio-based W-Modbus.

GW-wModbus

Up to 100 nodes can communicate with each other over a long distance (up to 500 m in a free field). An electrically isolated RS485 transceiver is used on the wired side (bus parameters can be set via DIP switches).

The simple **setup of the wireless network** and the connection stability enable existing systems to be easily expanded with wireless W-Modbus sensors. Even mixed configurations of wired and radio-based Modbus units can be easily integrated into existing network topologies via the W-Modbus gateway. For this purpose, there are two operating modes available depending on the unit type.

Gateway operation for connection to an existing Modbus topology or directly to a DDC/PLC, serves as a base station for W-Modbus sensors (max. 100 wireless nodes). **Node** operation enables a wired Modbus sensor to be connected wirelessly to a W-Modbus network (max. 1 wired sensor). The extended **NodePro** mode (for "GW-wModbusPro unit type") is used to connect several wired Modbus sensors (max. 16 wired nodes).

The **innovative parametrisation** feature of the W-Modbus interface and the elimination of Modbus wiring means that the entire W-Modbus network can be pre-configured (pairing the W-Modbus nodes, parametrising the gateway). This means that the network can be installed and put into operation quickly and easily at the destination.

In **App mode**, the network setup can be checked and documented (PDF) using the **Lumenradio W-Modbus app** (Apple/Android). Other app functions also include installing firmware updates for the wireless module, changing unit names and recognising communication errors or duplicate addresses.

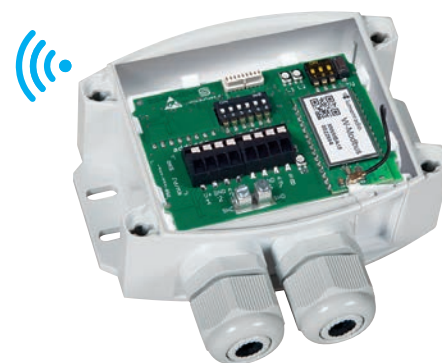

TECHNICAL DATA

Power supply:	24 V AC (± 20%); 15...36 V DC
Power consumption:	< 1.0 W / 24 VDC; < 1.4 VA / 24 VAC
Communication:	Modbus RTU (RS485 interface for RTU cable) and W-Modbus (Wireless Modbus, AES-128 encrypted) frequency 2.4 GHz ISM, transmission power 100 mW
Range:	max. 500 m (open field) / approx. 50 - 70 m (inside buildings) between two wireless nodes
Wireless nodes:	max. 100 wireless nodes
Operating modes:	Gateway Basic function as a base station (DDC/PLC) Node Adapter function for max. 1 wired sensor NodePro Adapter function for max. 16 wired sensors (Type GW-wModbusPro) (can be changed via DIP switch)
Housing:	Plastic, UV-resistant, polyamide material, 30 % glass-globe reinforced, with quick-locking screws (slotted / Phillips head combination), colour traffic white (similar to RAL 9016)
Housing dimensions:	108 x 78.5 x 43.3 mm (Tyr 3 without display)
Cable connection:	Cable gland, plastic (2x M 20 x 1.5; with strain relief, exchangeable, inner diameter 8 - 13 mm)
Electrical connection:	0.2 - 1.5 mm², using push-in terminals
Ambient temperature:	-30...+70 °C
Permitted humidity:	< 95 % RH, non-precipitating air
Protection class:	III (according to EN 60 730)
Protection type:	IP65 (according to EN 60 529)
Standards:	CE-conformity according to EMC directive 2014 / 30 / EU, Radio Directive 2014 / 53 / EU (W-Modbus)

Connection diagram

GW-wModbus

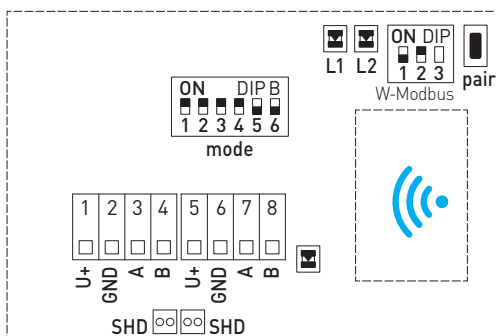

- DIP B „mode“:
Bus parameters (Baud rate, parity...)
- DIP „W-Modbus“:
Operating Mode (Gateway, Node)
- Teach-in key (pair)
- Network Status (L1)
- Connection quality (L2)
- Telegram Status
- Shielding (SHD)

For further technical information, see the operating instructions



NEW

Dimensional drawing
(mm)

GW-wModbus

GW-wModbus

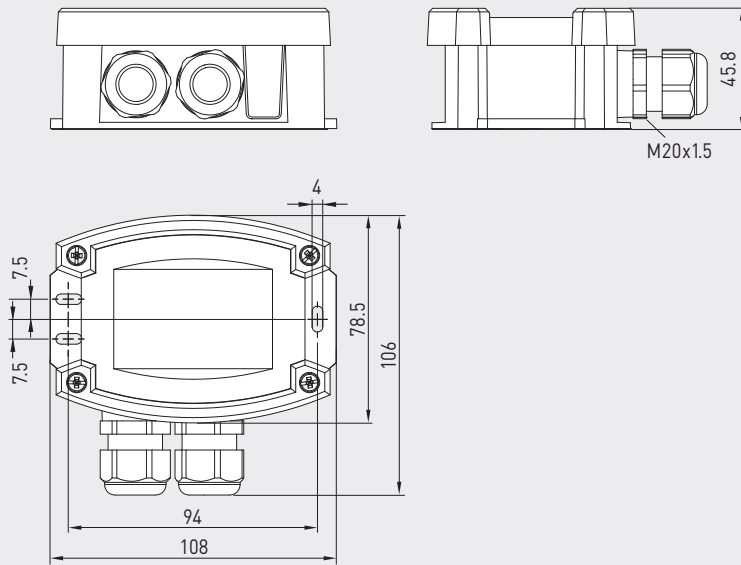

Modbus bus topology
(mixed configuration)

GW-wModbus

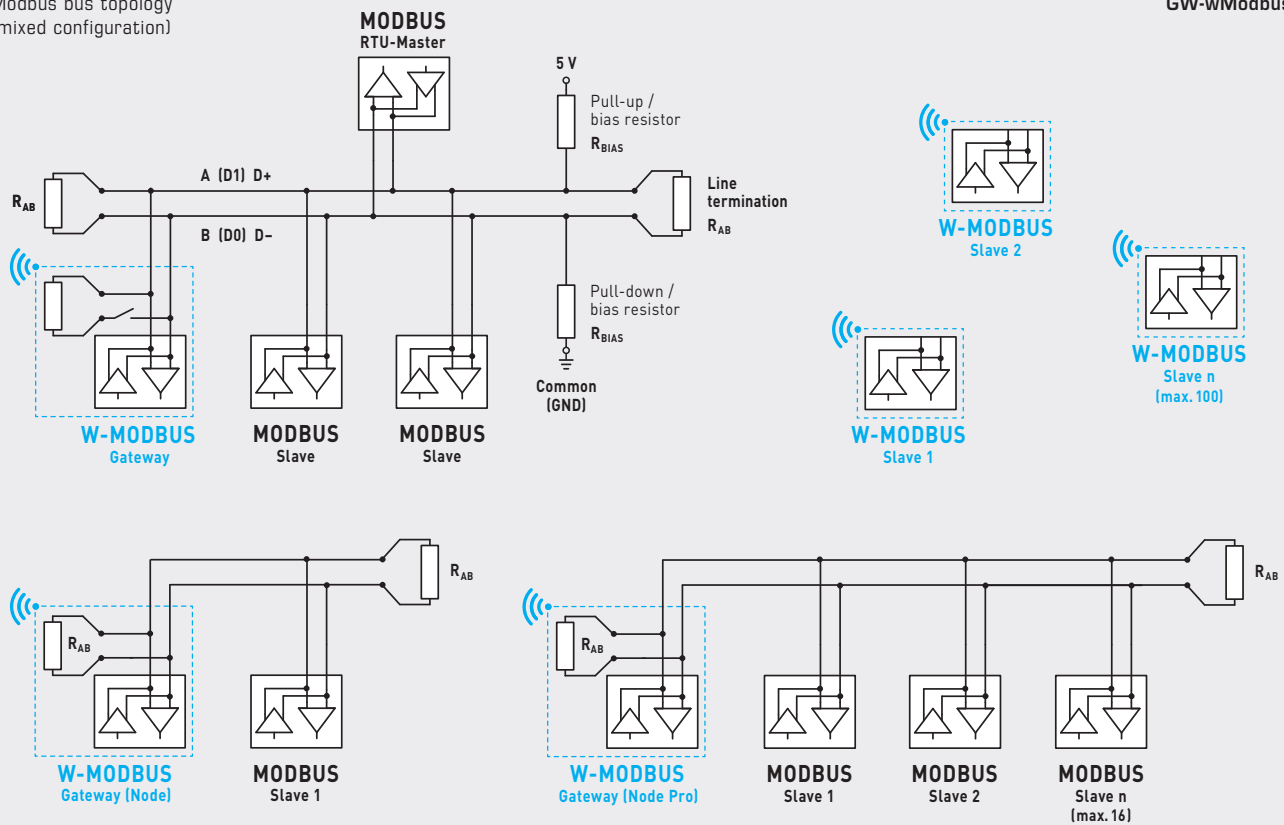

KYMASGARD® Gateway with W-Modbus module, for radio-based connection to Modbus networks

Type / WG02	Communication	Operating modes	Item no.	Price
GW-wModbus				
GW-wModbus	Modbus RTU / W-Modbus (Wireless)	Gateway + Node	1801-1211-1101-000	245,30 €
GW-wModbus Pro	Modbus RTU / W-Modbus (Wireless)	Gateway + Node Pro	1801-1211-1101-100	332,07 €

Note: "Pro" extends node operation from 1 to a maximum of 16 wired nodes