

Room, humidity and temperature sensor or measuring transducer for temperature, relative / absolute humidity, dew point, mixture ratio, enthalpy, in-wall in the panel switch programme, with Modbus connection

The room sensor and measuring transducer **HYGRASGARD® FSFTM - Modbus** in the in-wall housing, optionally with potentiometer, is used to measure the relative humidity and temperature of the air, and for setpoint adjustment. The following parameters are calculated internally from the measured values: relative humidity [% RH], absolute humidity [g/m³], mixture ratio [g/kg], dew point temperature [°C], enthalpy [kJ/kg] (ignoring atmospheric air pressure) and room temperature [°C]. The parameters are queried via the Modbus interface.

A digital, long-term stable sensor is used for humidity and temperature measurement. Relative humidity [% RH] is the quotient of water vapour partial pressure divided by the saturation vapour pressure at the respective gas temperature.

The in-wall sensor is mounted in high-quality panel switch programmes, ideally of the brands Gira, Berker, Merten, Jung, Siemens or Busch-Jaeger (using in-wall adapters, no setpoint adjustment possible) either individually or in combination with light switches, socket outlets, etc.

It is used in non-aggressive, dust-free environments, in refrigeration, air conditioning and clean room technology, and in interior rooms, such as living rooms, offices, hotels, etc.

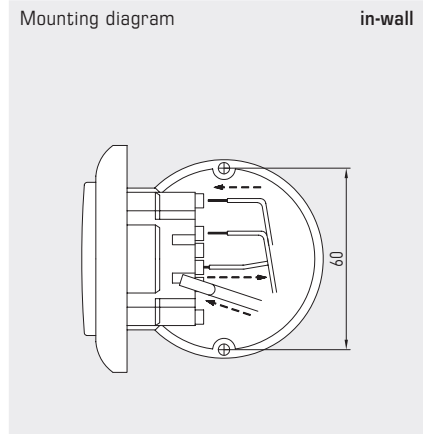

TECHNICAL DATA

Power supply:	24 V AC / DC (± 10 %)
Power consumption:	< 1.1 W / 24 V DC ; < 2.2 VA / 24 V AC
Data points:	temperature [°C], relative humidity [% RH] absolute humidity [g/m³], dew point [°C], mixing ratio [g/kg], enthalpy [kJ/kg] and setpoint potentiometer (no setpoint adjustment possible with Busch-Jaeger)
Bus protocol:	Modbus (RTU mode), address range 0...247 selectable
Signal filtering:	4 s / 32 s

HUMIDITY

Sensor:	digital humidity sensor, with integrated temperature sensor, low hysteresis, high long-term stability
Long-term stability:	± 1 % per year
Measuring range, humidity::	0...100% RH
Operating range, humidity:	0...95% RH (non-precipitating air)
Accuracy, humidity:	typically ± 3.0% (20...80% RH) at +25 °C, otherwise ± 5.0%

TEMPERATURE

Measuring range:	0...+50 °C
Accuracy, temperature:	typically ± 0.8 K at +25 °C

Mounting:	in-wall flush box Ø 55 mm
Electrical connection:	1.0 - 2.5 mm², via plug terminals
Ambient temperature:	Storage -35...+85 °C; Operation 0...+50 °C
Permitted humidity:	max. 90% RH, non-precipitating air
Medium:	clean air and other non-aggressive, non-combustible gases
Protection class:	III (according to EN 60 730)
Protection type:	IP 20 (according to 60 529)
Standards:	CE-conformity according to EMC Directive 2014 / 30 / EU

SWITCH PROGRAMME

Manufacturer:	GIRA System 55 (other switch programmes, manufacturers, colours as well as prices available upon request.)
Housing:	plastic, the standard colour is pure glossy white (similar to RAL 9010) (other colours are available upon request with colour variants depending on the respective light switch programme)

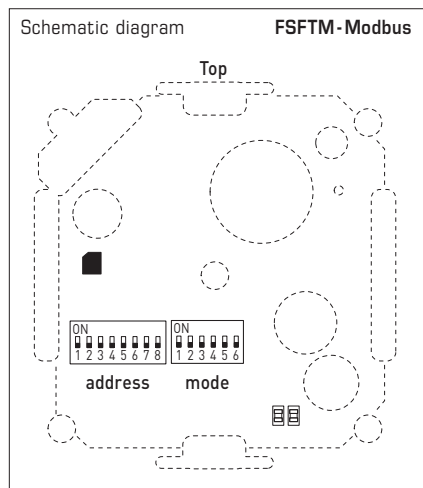
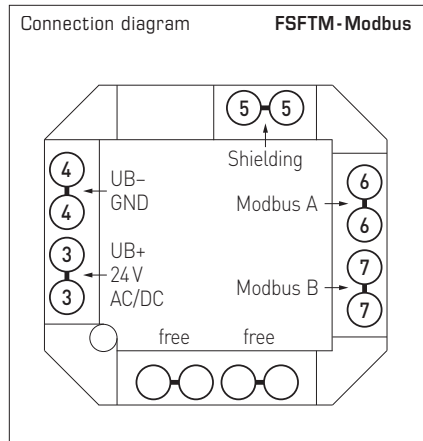



S+S REGELTECHNIK

Room, humidity and temperature sensor or measuring transducer for temperature, relative / absolute humidity, dew point, mixture ratio, enthalpy, in-wall in the panel switch programme, with Modbus connection

Dimensional drawing

FSFTM -Modbus

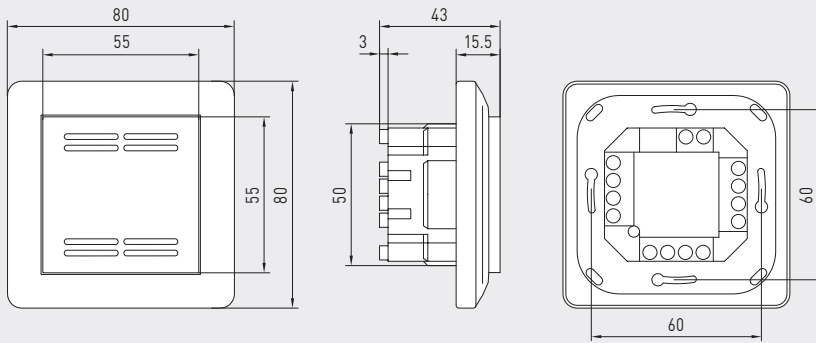

FSFTM -Modbus Standard



Dimensional drawing

FSFTM -Modbus -P

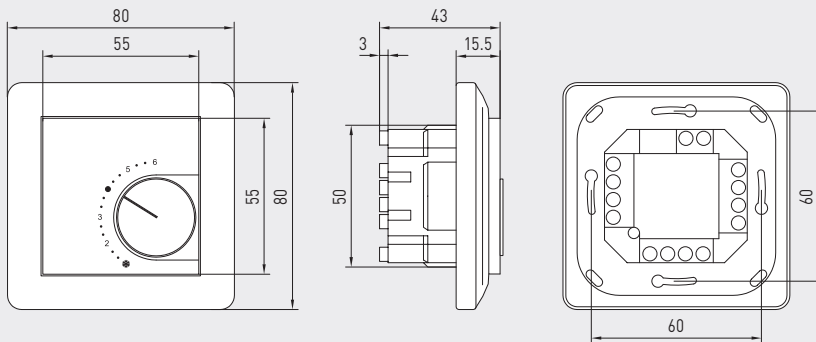

FSFTM -Modbus -P with potentiometer



HYGRASGARD® FSFTM -Modbus Room temperature and humidity sensor, in-wall

Type / WG02	Measuring Range	Temperature	Control element	Output	Item No.	Price
FSFTM -Modbus	Humidity (base value)					
FSFTM-Modbus	0...100% RH (default) 0...80 g/kg (MV) 0...80 g/m³ (AH) 0...85 kJ/kg (ENT.) 0...+50 °C (DP)	0...+50 °C	-	Modbus	1201-9226-1000-162	320,48 €
FSFTM-Modbus P	0...100% RH (default) 0...80 g/kg (MV) 0...80 g/m³ (AH) 0...85 kJ/kg (ENT.) 0...+50 °C (DP)	0...+50 °C	Potentiometer	Modbus	1201-9226-1400-282	346,65 €

Data points: relative humidity [% RH], absolute humidity [g/m³], mixture ratio [g/kg], dew point temperature [°C], enthalpy [kJ/kg] (ignoring atmospheric air pressure), temperature [°C] and setpoint potentiometer

ACCESSORIES

KA2-Modbus	Communication adapter (with USB and RS485 interface) for system connection (incl. quick-start software)	1906-1200-0000-100	236,11 €
LA-Modbus	Line termination device (with terminating resistor) as an active bus termination of RS485 networks	1906-1300-0000-100	88,05 €