

Room humidity, temperature and CO2 sensor or measuring transducer, in-wall in the panel switch programme, with Modbus connection

The room sensor and measuring transducer **AERASGARD® FSFTM - CO2 - Modbus** in the in-wall housing, optionally with potentiometer, is used to measure the CO2 content, relative humidity and temperature of the air, and for setpoint adjustment. The measured values are queried via the Modbus interface.

The CO2 content of the air is measured using an optical NDIR sensor (non-dispersive infra-red technology). A digital, long-term stable sensor is used for humidity and temperature measurement. Relative humidity [% RH] is the quotient of water vapour partial pressure divided by the saturation vapour pressure at the respective gas temperature.

The in-wall sensor is mounted in high-quality panel switch programmes, ideally of the brands Gira, Berker, Merten, Jung, Siemens or Busch-Jaeger (using in-wall adapters, no setpoint adjustment possible) either individually or in combination with light switches, socket outlets, etc.

It is used in non-aggressive, dust-free environments, in refrigeration, air conditioning and clean room technology, and in interior rooms, such as living rooms, offices, hotels, etc.

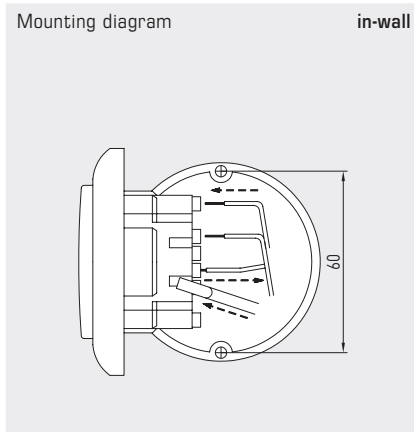

TECHNICAL DATA

Power supply:	24 V AC / DC (± 10 %)
Power consumption:	< 4.4 W / 24 V DC ; < 6.4 VA / 24 V AC
Data points:	relative humidity [% RH], temperature [°C], CO2 content of the air [ppm] as well as setpoint potentiometer (no setpoint adjustment possible with Busch-Jaeger)
Bus protocol:	Modbus (RTU mode), address range 0... 247 selectable
Signal filtering:	4 s / 32 s

CARBON DIOXIDE (CO2)

Sensor, CO2:	optical NDIR sensor (non-dispersive infra-red technology), with manual calibration (via zero button) and automatic calibration
Long-term stability:	< 2 % in 15 years
Measuring range, CO2:	0...5000 ppm
Measuring accuracy, CO2:	typically ± 30 ppm ± 3 % of measured value
Temperature dependence, CO2:	± 5 ppm / °C or ± 0.5 % of measured value / °C (whichever is higher)
Pressure dependence:	± 0.13 % / mm Hg
Gas exchange:	by diffusion
Warm up time:	approx. 1 hour
Response time:	< 2 minutes

HUMIDITY

Sensor:	digital humidity sensor with integrated temperature sensor , low hysteresis, high long-term stability
Long-term stability:	± 1 % per year
Measuring range, humidity:	0...100 % RH
Operating range, humidity:	0...95 % RH (non-precipitating air)
Accuracy, humidity:	typically ± 3.0 % (20...80 % RH) at +25 °C, otherwise ± 5.0 %

TEMPERATURE

Measuring range:	0...+50 °C
Accuracy, temperature:	typically ± 0.8 K at +25 °C

Mounting:	in-wall flush box Ø 55 mm
Electrical connection:	1.0 - 2.5 mm², via plug terminals
Ambient temperature:	Storage -35...+85 °C; Operation 0...+50 °C
Permitted humidity:	max. 90 % RH, non-precipitating air
Medium:	clean air and other non-aggressive, non-combustible gases
Protection class:	III (according to EN 60 730)
Protection type:	IP 20 (according to 60 529)
Standards:	CE-conformity according to EMC Directive 2014 / 30 / EU

SWITCH PROGRAMME

Manufacturer:	GIRA System 55 (other switch programmes, manufacturers, colours as well as prices available upon request)
Housing:	plastic, the standard colour is pure glossy white (similar to RAL 9010) (other colours are available upon request with colour variants depending on the respective light switch programme)

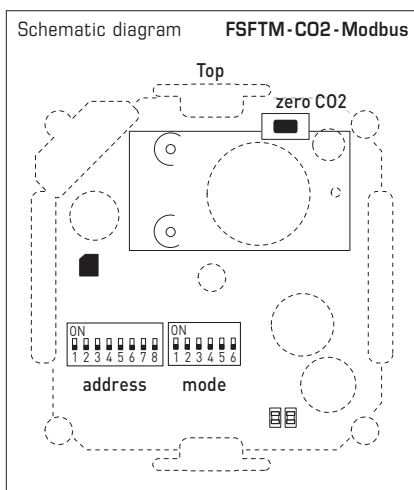
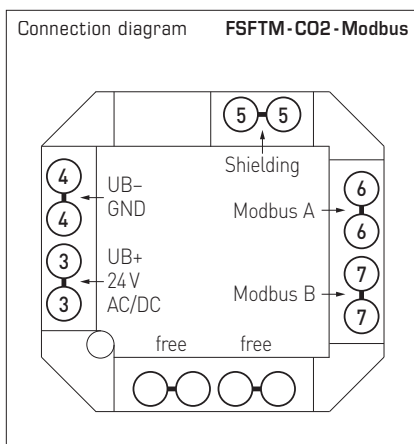



S+S REGELTECHNIK

Room humidity, temperature and CO2 sensor or measuring transducer, in-wall in the panel switch programme, with Modbus connection

Dimensional drawing

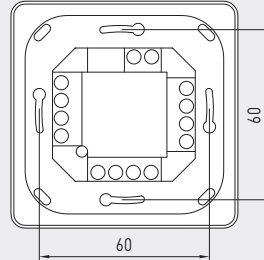
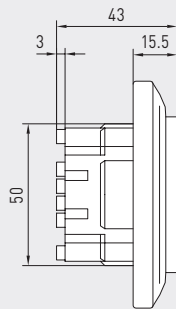
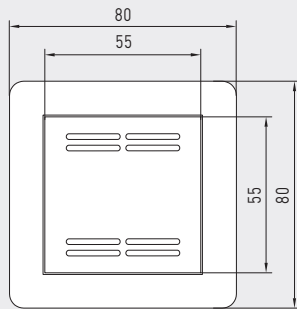

FSFTM - CO2 - Modbus

FSFTM - CO2 - Modbus
Standard



Dimensional drawing

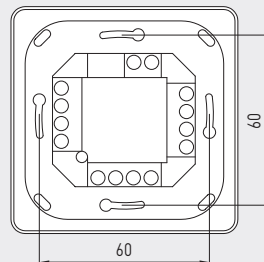
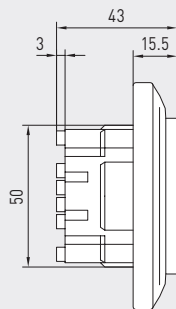
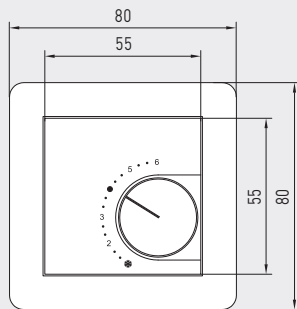

FSFTM - CO2 - Modbus - P

FSFTM - CO2 - Modbus - P
with potentiometer



AERASGARD® FSFTM - CO2 - Modbus Room temperature humidity and CO2 sensor, in-wall

Type / WG02	Measuring Range CO2	Humidity	Temperature	Control element	Output	Item No.	Price
FSFTM - CO2 - Modbus							
FSFTM-CO2-Modbus	0...5000 ppm	0...100% RH	0...+50 °C	-	Modbus	1501-9226-6001-162	413,37 €
FSFTM-CO2-Modbus P	0...5000 ppm	0...100% RH	0...+50 °C	Potentiometer	Modbus	1501-9226-6501-282	510,17 €

Data points: relative humidity [% RH], temperature [°C], CO2 content of the air (ppm) and setpoint potentiometer

ACCESSORIES

KA2-Modbus	Communication adapter (with USB and RS485 interface) for system connection (incl. quick-start software)	1906-1200-0000-100	236,11 €
LA-Modbus	Line termination device (with terminating resistor) as an active bus termination of RS485 networks	1906-1300-0000-100	88,05 €