

**Room CO2 and temperature sensor or measuring transducer,
in-wall in the panel switch programme,
with active output**

The room sensor **AERASGARD® FSCO2 / FSTM-CO2** in the in-wall housing is used for measuring the CO2 content and temperature of the air. It converts the measured values into a standard signal of 0-10 V.

The CO2 content of the air is measured using an optical NDIR sensor (non-dispersive infra-red technology). A digital, long-term stable sensor is used for temperature measurement.

The in-wall sensor is mounted in high-quality panel switch programmes, ideally of the brands Gira, Berker, Merten, Jung, Siemens or Busch-Jaeger (using in-wall adapters) either individually or in combination with light switches, socket outlets, etc.

It is used in non-aggressive, dust-free environments, in refrigeration, air conditioning and clean room technology, and in interior rooms, such as living rooms, offices, hotels, etc.

TECHNICAL DATA

Power supply:	24 V AC / DC (± 10 %)
Power consumption:	< 1.5 W / 24 V DC; < 2.9 VA / 24 V AC

CARBON DIOXIDE (CO2)

Sensor, CO2:	optical NDIR sensor (non-dispersive infra-red technology), with manual calibration (via zero button) and automatic calibration (fixed)
Long-term stability:	< 2 % in 15 years
Measuring range, CO2:	0...2000 ppm
Output, CO2:	0-10 V
Accuracy CO2:	typically ± 30 ppm ± 3 % of measured value
Temperature dependence:	± 5 ppm / °C or ± 0.5 % of measured value / °C (whichever is higher)
Pressure dependence:	± 0.13 % / mm Hg
Gas exchange:	by diffusion
Warm up time:	approx. 1 hour
Response time:	< 2 minutes

TEMPERATURE

Sensor:	digital temperature sensor , low hysteresis, high long-term stability
Long-term stability:	± 1 % per year
Measuring range:	0...+50 °C
Accuracy, temperature:	typically ± 0.8 K at +25 °C
Output, temperature:	0-10 V

Mounting:	in-wall flush box Ø 55 mm
Electrical connection:	1.0-2.5 mm ² , via plug terminals
Ambient temperature:	storage -35...+85 °C; operation 0...+50 °C
Permitted humidity:	max. 90 % RH, non-precipitating air
Medium:	clean air and other non-aggressive, non-combustible gases
Protection class:	III (according to EN 60 730)
Protection type:	IP 20 (according to 60 529)
Standards:	CE-conformity according to EMC Directive 2014 / 30 / EU

SWITCH PROGRAMME

Manufacturer:	GIRA System 55 (other switch programmes, manufacturers, colours as well as prices available upon request)
Housing:	plastic, the standard colour is pure glossy white (similar to RAL 9010) (other colours are available upon request with colour variants depending on the respective light switch programme)

Mounting diagram

in-wall

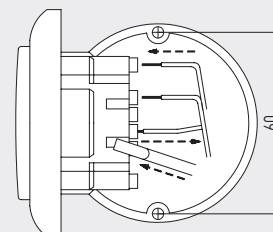

Connection diagram

FSCO2

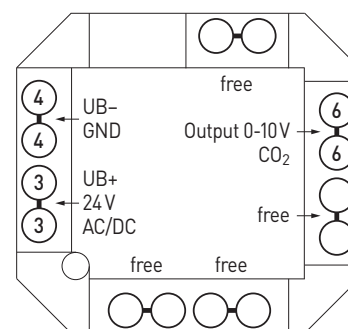

Connection diagram

FSTM-CO2

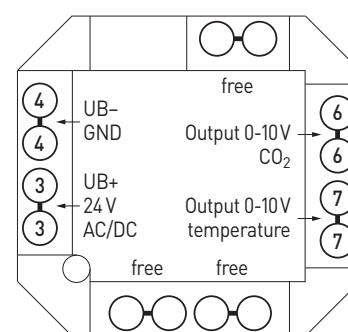

Schematic diagram

FSFTM-CO2

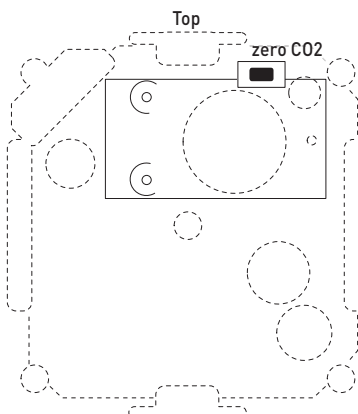



S+S REGELTECHNIK

AERASGARD® FSC02
AERASGARD® FSTM-C02

Room CO2 and temperature sensor or measuring transducer,
in-wall in the panel switch programme,
with active output



Dimensional drawing

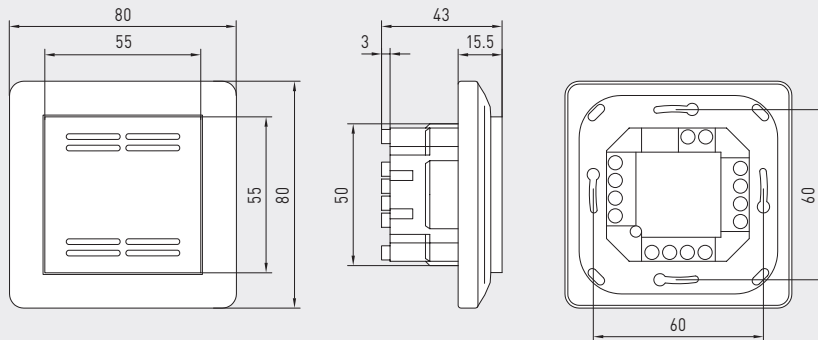

FSC02
FSTM-C02

FSC02
FSTM-C02



CO2 content table
MR: 0...2000 ppm

ppm	U _A [V]
0	0.00
350	1.75
400	2.00
450	2.25
500	2.50
550	2.75
600	3.00
700	3.50
800	4.00
900	4.50
Continued to the right ...	

ppm	U _A [V]
1000	5.0
1100	5.5
1200	6.0
1300	6.5
1400	7.0
1500	7.5
1600	8.0
1700	8.5
1800	9.0
1900	9.5
2000	10.0

Temperature table
MR: 0...+50 °C

°C	U _A [V]
0	0.0
5	1.0
10	2.0
15	3.0
20	4.0
25	5.0
30	6.0
35	7.0
40	8.0
45	9.0
50	10.0

AERASGARD® FSC02 Room CO2 sensor or measuring transducer, in-wall
AERASGARD® FSTM-C02 Room temperature and CO2 sensor or measuring transducer, in-wall

Type / WG02	Measuring Range CO2	Temperature	Output CO2	Temperature	Item No.	Price
FSC02						
FSC02-U	0...2000 ppm	-	0-10 V	-	1501-9120-1001-162	372,82 €
FSTM-C02						
FSTM-C02-U	0...2000 ppm	0...+50 °C	0-10 V	0-10 V	1501-9122-1001-162	378,05 €

